

SERIES 4100A IMPACT RESISTANT SINGLE HUNG WINDOW

1) THIS PRODUCT HAS BEEN DESIGNED & TESTED TO COMPLY WITH THE REQUIREMENTS OF THE FLORIDA BUILDING CODE, INCLUDING THE HIGH VELOCITY HURRICANE ZONE (HVHZ).

2) SHUTTERS ARE NOT REQUIRED WHEN USED IN WIND-BORNE DEBRIS REGIONS.

3) MASONRY ANCHORS MAY BE USED INTO WOOD AS PER TABLE 2. ALL WOOD BUCKS LESS THAN 1-1/2" THICK ARE TO BE CONSIDERED 1X INSTALLATIONS. 1X WOOD BUCKS ARE OPTIONAL IF UNIT IS INSTALLED DIRECTLY TO SUBSTRATE. WOOD BUCKS DEPICTED AS 2X ARE 1-1/2" THICK OR GREATER. 1X AND 2X BUCKS (WHEN USED) SHALL BE DESIGNED TO PROPERLY TRANSFER LOADS TO THE STRUCTURE. WOOD BUCK DESIGN AND INSTALLATION IS THE RESPONSIBILITY OF THE ENGINEER OR ARCHITECT OF RECORD.

4) ANCHOR EMBEDMENT TO BASE MATERIAL SHALL BE BEYOND WALL DRESSING OR STUCCO. USE ANCHORS OF SUFFICIENT LENGTH. INSTALLATION ANCHORS SHOULD BE SEALED. OVERALL SEALING/FLASHING STRATEGY FOR WATER RESISTANCE OF INSTALLATION SHALL BE DONE BY OTHERS AND IS BEYOND THE SCOPE OF THESE INSTRUCTIONS.

5) SHIMS ARE REQUIRED AT EACH FLANGE ANCHOR LOCATION WHERE THE PRODUCT IS NOT FLUSH TO THE SUBSTRATE. USE SHIMS CAPABLE OF TRANSFERRING APPLIED LOADS. WOOD BUCKS, BY OTHERS, MUST BE SUFFICIENTLY ANCHORED TO RESIST LOADS IMPOSED ON THEM BY THE WINDOW.

6) THE ANCHORAGE METHODS SHOWN HAVE BEEN DESIGNED TO RESIST THE WIND LOADS CORRESPONDING TO THE REQUIRED DESIGN PRESSURE. THE 33-1/3% STRESS INCREASE HAS NOT BEEN USED IN THE DESIGN OF THIS PRODUCT. THE 1.6 LOAD DURATION FACTOR WAS USED FOR THE EVALUATION OF ANCHORS INTO WOOD. ANCHORS THAT COME INTO CONTACT WITH OTHER DISSIMILAR MATERIALS SHALL MEET THE REQUIREMENTS OF THE FLORIDA BUILDING CODE FOR CORROSION RESISTANCE.

DESIGN PRESSURE RATING	IMPACT RATING
+55/-65 PSF	RATED FOR LARGE & SMALL MISSILE IMPACT RESISTANCE

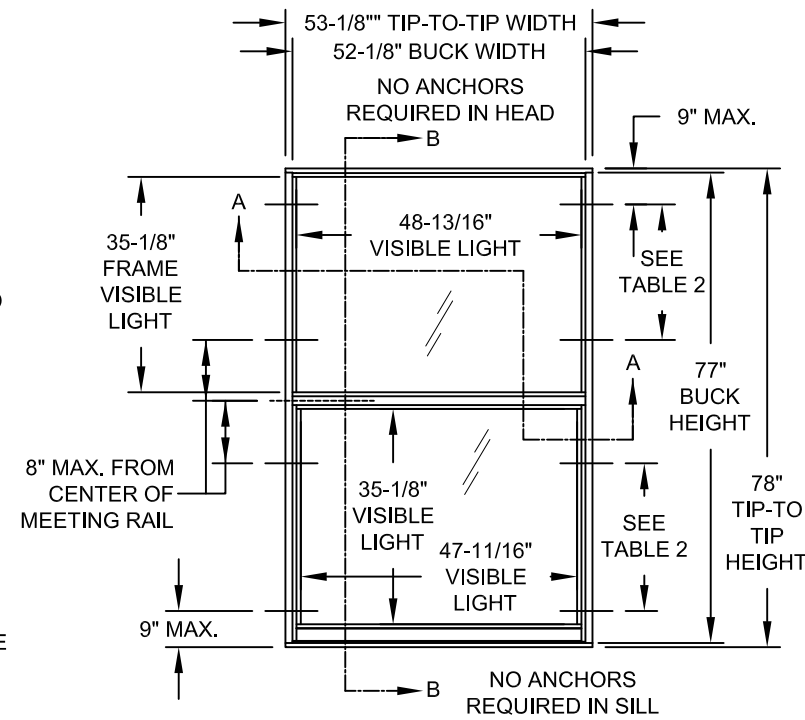

TYP. FLANGE FRAME ANCHOR LOCATIONS @ MAX. SIZE

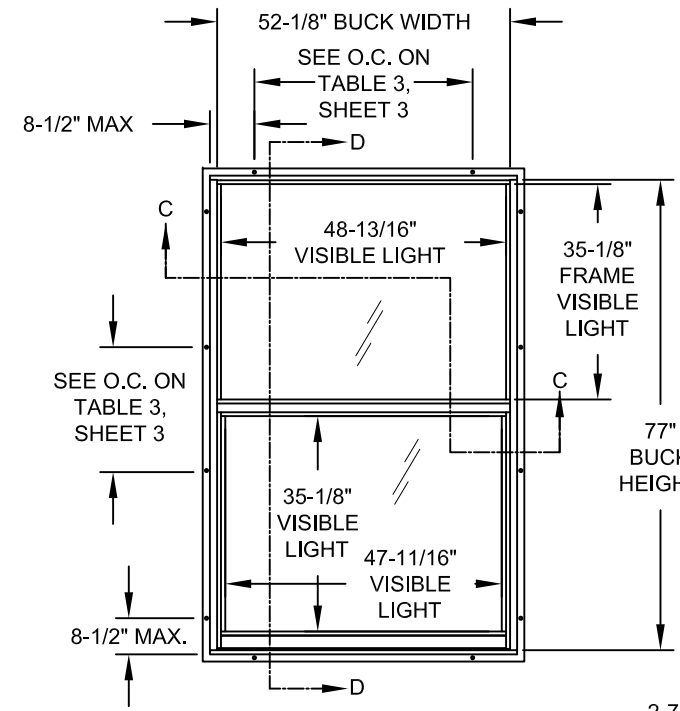

TYP. INTEGRAL FIN FRAME ANCHOR LOCATIONS @ MAX. SIZE (INSTALLED WITH SCREWS)

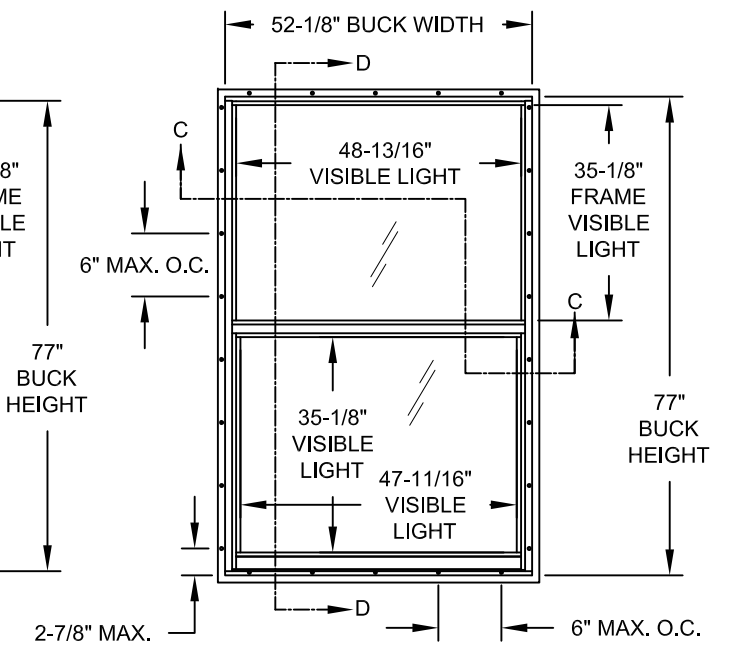

TYP. INTEGRAL FIN FRAME ANCHOR LOCATIONS @ MAX. SIZE (INSTALLED WITH NAILS)

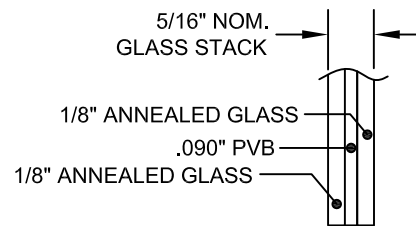

5/16" LAMI. GLAZING GLASS TYPE 1

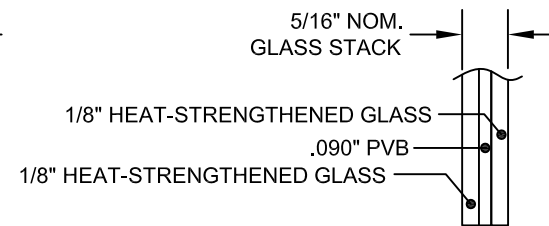

5/16" LAMI. GLAZING GLASS TYPE 2

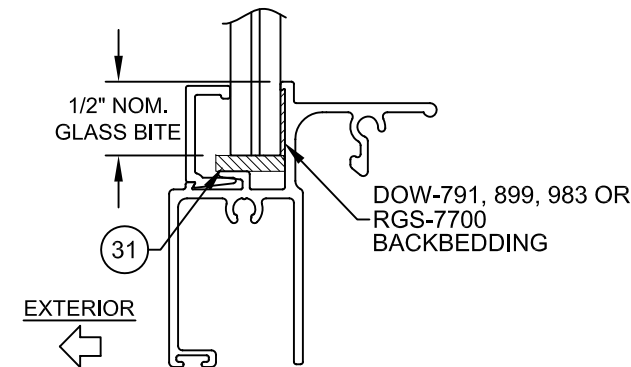

TYP. GLAZING DETAIL

Oriel configuration allowed provided that the frame visible light height of 35-1/8" and the frame height, as shown above, is not exceeded.

TABLE 1:

Laminated Glass Types	
1	1/8" Annealed, 0.090" PVB, 1/8" Annealed
2	1/8" Heat-strengthened, 0.090" PVB, 1/8" Heat-strengthened

INTERLAYER MAY BE SAFLEX PVB OR TROSIFOL PVB

Title: SH WINDOW INSTALLATION		Drawn By: J ROSOWSKI	
Description: GENERAL NOTES & ELEVATION		Date: 09/20/17	
Revision: ADDED ULTRACON+ ANCHOR		Rev. By: JR Rev. Date: 08/27/20	
Series/Model: SH-4100A	Scale: NTS	Sheet: 1 OF 4	Drawing No. SH4100FLPA
		Rev: E	

Impact Resistant Windows & Doors
WE'RE STRONGER™

3780 W. 104th Street, Hialeah, FL 33018
Tel: 305.593.6590 | Fax: 305.593.6592

PREPARED BY LYNN MILLER
1070 TECHNOLOGY DRIVE
N. VENICE, FL 34275
(941) 480-1600

COPYRIGHT © 2020 CGI WINDOWS & DOORS, LIMITED LICENSE TO MAKE COPIES FOR PERMITTING.
REGISTRATION #29296

ANTHONY LYNN MILLER
LICENSE
No. 58705
9/3/20
STATE OF FLORIDA
PROFESSIONAL ENGINEER
A. LYNN MILLER, P.E.
P.E.# 58705

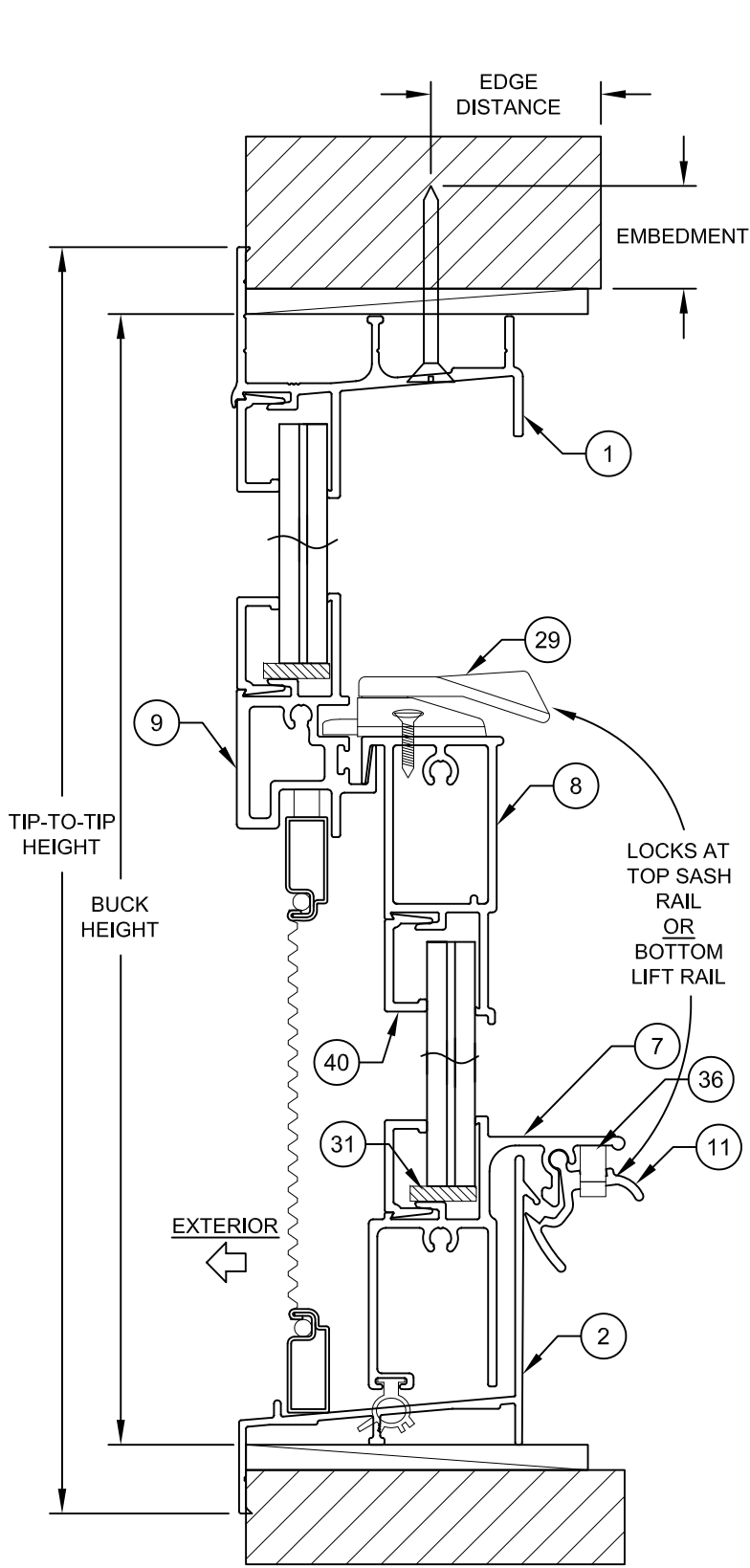

NO ANCHORS REQUIRED IN FLANGE FRAME SILL

VERTICAL SECTION B-B

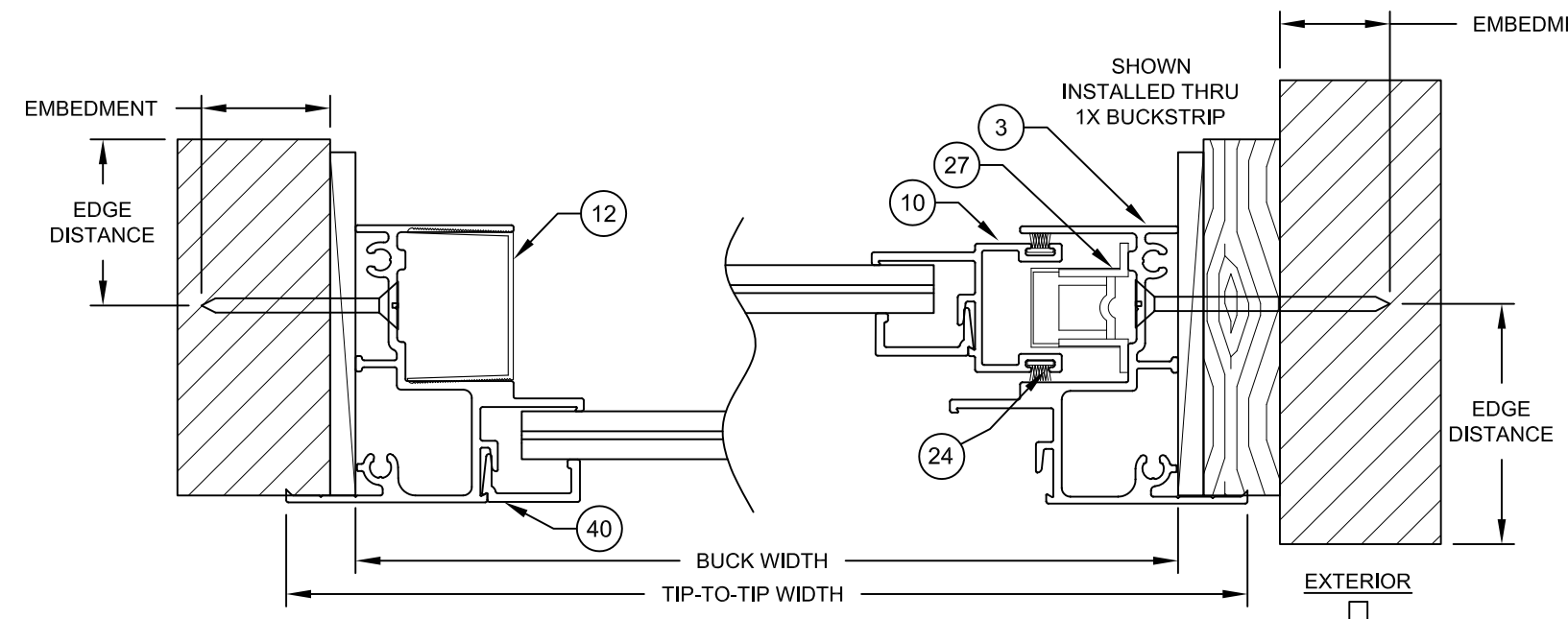

HORIZONTAL SECTION A-A

- NOTES**
- 1) USE ONLY SUBSTRATE APPROPRIATE ANCHORS LISTED IN TABLE 2. FOLLOW EMBEDMENT AND EDGE DISTANCE LIMITS. ANY INSTALLATION OPTION SHOWN MAY BE USED ON ANY SIDE OF THE WINDOW.
 - 2) MASONRY ANCHORS MAY BE USED INTO WOOD AS PER TABLE 2. ALL WOOD BUCKS LESS THAN 1-1/2" THICK ARE TO BE CONSIDERED 1X INSTALLATIONS. 1X WOOD BUCKS ARE OPTIONAL IF UNIT IS INSTALLED DIRECTLY TO SUBSTRATE. WOOD BUCKS DEPICTED AS 2X ARE 1-1/2" THICK OR GREATER. 1X AND 2X BUCKS (WHEN USED) SHALL BE DESIGNED TO PROPERLY TRANSFER LOADS TO THE STRUCTURE. WOOD BUCK DESIGN AND INSTALLATION IS THE RESPONSIBILITY OF THE ENGINEER OR ARCHITECT OF RECORD.
 - 3) SEE SHEET 1 & TABLE 2 FOR SPACING REQUIREMENTS.
 - 4) MAX. SHIM THICKNESS TO BE 1/4".
 - 5) GLASS SHOWN IS FOR ILLUSTRATIVE PURPOSES ONLY AND MAY DIFFER TO MEET DESIGN REQUIREMENTS.

TABLE 2: THROUGH-FRAME ANCHORS

Anchor	Substrate	Minimum Edge Distance	Minimum Embedment	Max. O.C. (Above / Below Meeting Rail)
#12 Steel SMS Screw (G5)	P.T. Southern Pine (SG = .55)	9/16"	1-3/8"	21" / 23"
	Aluminum, 6063-T5 min.	3/8"	0.078"	21" / 23"
	Steel Stud, Gr. 33 min.	3/8"	0.045" (20 Ga)	21" / 23"
	A36 Steel	3/8"	0.050"	21" / 23"
1/4" Steel Ultracon	P.T. Southern Pine (SG = .55)	1"	1-3/8"	21" / 23"
	Concrete (min. 2.9 ksi)	1-1/8"	1-3/8"	21" / 23"
	Grouted CMU, (ASTM C-90)	2-1/2"	1-3/4"	21" / 23"
1/4" Steel Ultracon+	P.T. Southern Pine (SG = .55)	1"	1-3/8"	21" / 23"
	Concrete (min. 3.0 ksi)	1-7/8"	1-3/8"	21" / 23"
	Grouted CMU, (ASTM C-90)	2-1/2"	1-3/4"	21" / 23"
1/4" 410 SS CreteFlex	P.T. Southern Pine (SG = .55)	1"	1-3/8"	21" / 23"
	Concrete (min. 3.35 ksi)	1"	1-3/4"	21" / 23"
	Concrete (min. 3.35 ksi)	2-1/2"	1"	21" / 23"
1/4" 410 SS CreteFlex	UngROUTED CMU, (ASTM C-90)	1-1/8"	1-1/4"	12-1/4" / 12-1/4"
	UngROUTED CMU, (ASTM C-90)	1"	1-1/4"	12-1/4" / 12-1/4"

- 1) ANCHOR MUST EXTEND A MINIMUM OF 3 THREADS BEYOND ANY METAL SUBSTRATE.
- 2) "UNGRouted CMU" VALUES MAY BE USED FOR GRouted CMU APPLICATIONS.

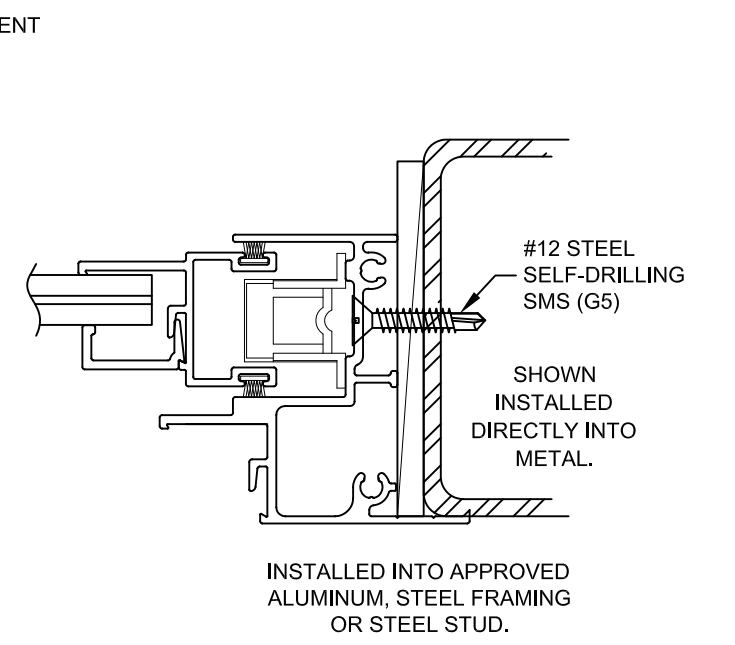

INSTALLED INTO APPROVED ALUMINUM, STEEL FRAMING OR STEEL STUD.

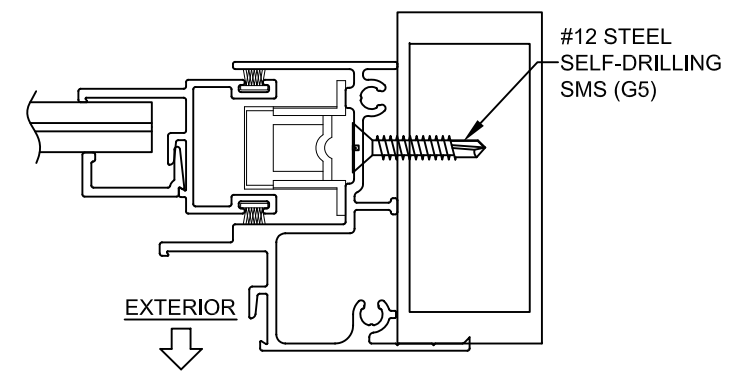

MULLION SECTION APPROVED MULLION, MAY BE VERTICAL OR HORIZONTAL.

Title: SH WINDOW INSTALLATION		Drawn By: J ROSOWSKI	
Description: INSTALLATION FOR FLANGE WINDOWS		Date: 09/20/17	
Revision: ADDED ULTRACON+ ANCHOR		Rev. By: Rev. Date: JR 08/27/20	
Series/Model: SH-4100A	Scale: NTS	Sheet: 2 OF 4	Drawing No. Rev: SH4100FLPA E

Impact Resistant Windows & Doors
WE'RE STRONGER™

3780 W. 104th Street, Hialeah, FL 33018
Tel: 305.593.6590 | Fax: 305.593.6592

PREPARED BY LYNN MILLER
1070 TECHNOLOGY DRIVE
N. VENICE, FL 34275
(941) 480-1600

COPYRIGHT © 2020 CGI WINDOWS & DOORS, LIMITED LICENSE TO MAKE COPIES FOR PERMITTING.
REGISTRATION #29296

ANTHONY LYNN MILLER
LICENSE
No. 58705
9/3/20
STATE OF FLORIDA
PROFESSIONAL ENGINEER
A. LYNN MILLER, P.E.
P.E.# 58705

TABLE 4:

Item #	Description
1	Flange Frame Head
2	Flange Frame Sill
3	Flange Frame Jamb
4	Integral Fin Frame Head
5	Integral Fin Frame Sill
6	Integral Fin Frame Jamb
7	Sash Bottom Rail
8	Sash Top Rail
9	HD Fixed Meeting Rail
10	Sash Side Rail
11	Sash Bottom Lock
12	Vinyl Sash Stop
20	Vinyl Bulb, Flex PVC 70
21	Frame Corner Gasket, Polyethelyne, opt.
22	Sash Corner Gasket, Polyethelyne, opt
23	Fixed Meeting Rail Plug, Rigid PVC
24	Wstp., 187" X .230" Fin Seal
25	Frame/Sash Corner Sealant, opt.
26	Balance Take-out Clip
27	Balance
28	Sash Cam, Nylon
29	Sweep Latch, Zinc
30	#6 X 5/8" Ph. Fl. SMS Latch Screws
31	Setting Block 1/8" x 1/2" x 1", EPDM
36	Sash Bottom Lock Spring
38	Glazing Sealant
40	Glass Bead (Lam. Glass)

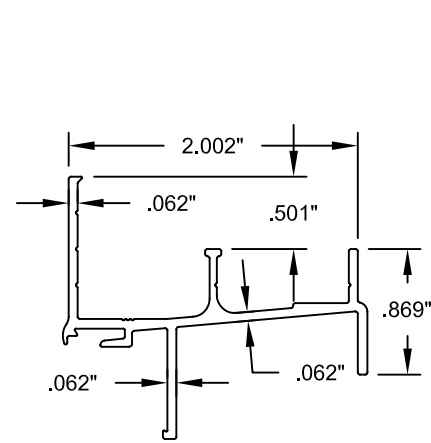

1 FLANGE FRAME HEAD
6063-T6 ALUMINUM

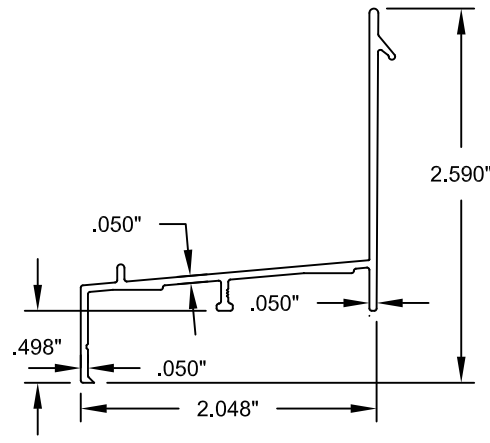

2 FLANGE FRAME SILL
6063-T6 ALUMINUM

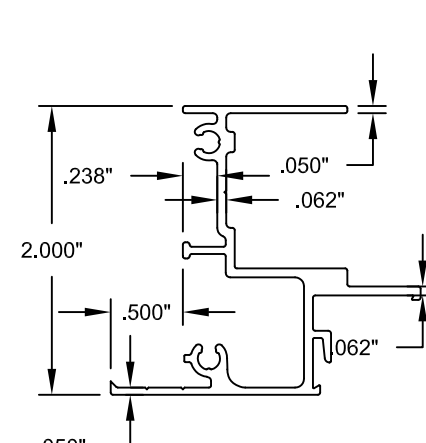

3 FLANGE FRAME JAMB
6063-T6 ALUMINUM

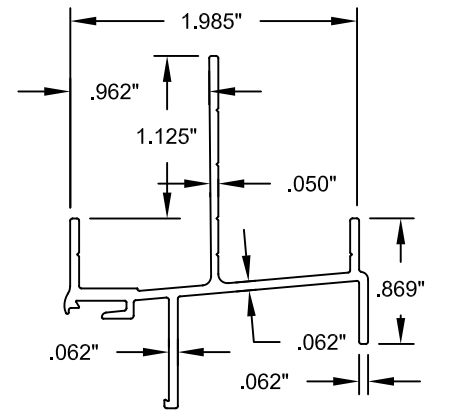

4 INTEGRAL FIN FRAME HEAD
6063-T5 ALUMINUM

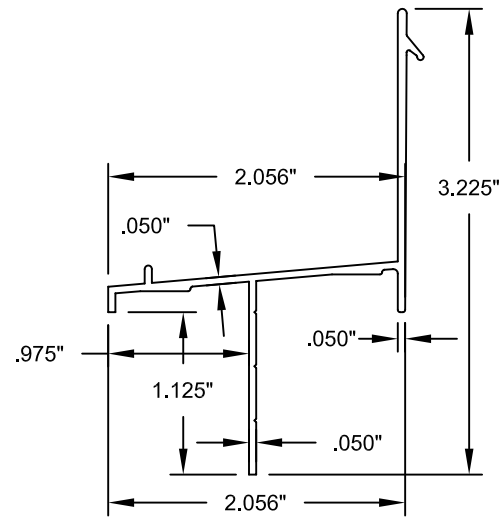

5 INTEGRAL FIN FRAME SILL
6063-T6 ALUMINUM

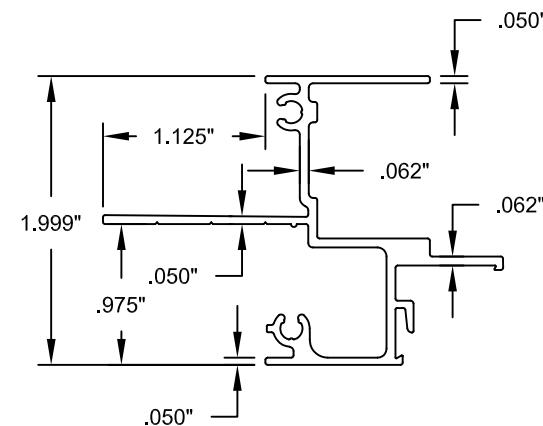

6 INTEGRAL FIN FRAME JAMB
6063-T6 ALUMINUM

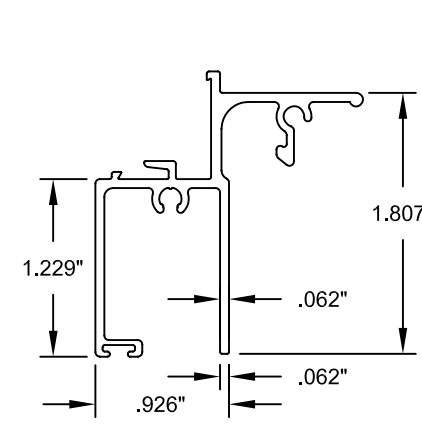

7 SASH BOTTOM RAIL
6063-T6 ALUMINUM

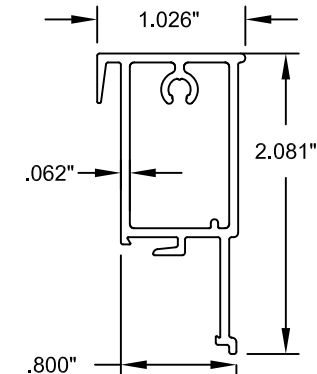

8 SASH TOP RAIL
6063-T6 ALUMINUM

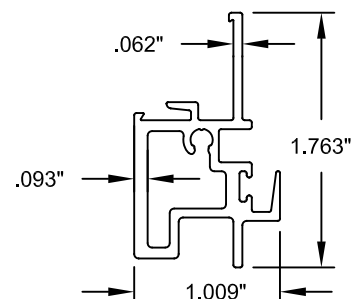

9 HD FIXED MEETING RAIL
6063-T6 ALUMINUM

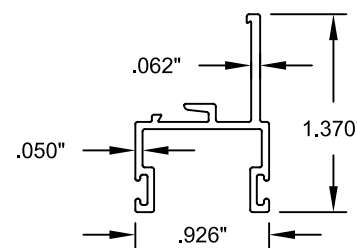

10 SASH SIDE RAIL
6063-T6 ALUMINUM

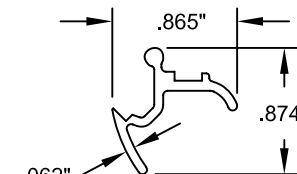

11 SASH BOTTOM LOCK RAIL
6063-T6 ALUMINUM

Title: SH WINDOW INSTALLATION		Drawn By: J ROSOWSKI	
Description: MATERIALS		Date: 09/20/17	
Revision: ADDED ULTRACON+ ANCHOR		Rev. By: Rev. Date: JR 08/27/20	
Series/Model: SH-4100A	Scale: NTS	Sheet: 4 OF 4	Drawing No.: SH4100FLPA
			Rev.: E

Impact Resistant Windows & Doors
WE'RE STRONGER™

3780 W. 104th Street, Hialeah, FL 33018
Tel: 305.593.6590 | Fax: 305.593.6592

PREPARED BY LYNN MILLER
1070 TECHNOLOGY DRIVE
N. VENICE, FL 34275
(941) 480-1600

COPYRIGHT © 2020 CGI WINDOWS & DOORS. LIMITED LICENSE TO MAKE COPIES FOR PERMITTING.
REGISTRATION #29296

ANTHONY LYNN MILLER
LICENSE
No. 58705
9/3/20
STATE OF FLORIDA
PROFESSIONAL ENGINEER
A. LYNN MILLER, P.E.
P.E.# 58705